

EFX-LE II

Audio Controller

OWNER'S MANUAL

Version 2.3x

Musicom 
Preserving Your Tone, Pure and Dynamic

Table of Contents

1. INTRODUCTION	3
1.1 Main Features	3
1.2 Specifications	4
1.3 Block Diagram	4
1.4 Front Panel	5
1.5 Rear Panel	6
2. BASIC OPERATION	7
2.1 Initial Power Up	7
2.2 Page 1	7
2.3 Page 2	8
2.4 Page 3	8
2.5 Page 4	8
3. SONG/SET MODE	9
3.1 SONG mode	9
3.2 SET mode	9
4. SETUP MODE	10
4.1 PRESET Menu	10
4.1.1 MIDI / Volume	10
4.1.2 Routing	13
4.2 SONGS/SET Menu	16
4.2.1 Edit Songs	16
4.2.2 Edit Sets	16
4.3 SWITCHES Menu	17
4.3.1 Assign as Preset Switch	18
4.3.2 Assign as IA Switch	19
4.3.3 Assign as Tap-Tempo Switch	21
4.3.4 Assign as Page+/Mute or Page-/Mute Switch	22
4.3.5 Assign as Page+/Save or Page-/Save Switch	22
4.3.6 Assign as Bank Up or Bank Down Switch	22
4.3.7 Assign as Volume.A+/- or Volume.B+/- Switch	23
4.3.8 Assign as BPM+ or BPM- Switch	23
4.4 TITLES Menu	24
4.4.1 Preset Title	24
4.4.2 Song Title	24
4.4.3 Sset Title	25
4.4.4 Page Title	25
4.4.5 Switch Titles	26
4.5 GLOBAL Menu	27
4.5.1 MIDI	27
4.5.2 Audio	29
4.5.3 Others	31
4.6 UTILITY Menu	32
4.6.1 Preset Copy	32
4.6.2 Song / Set / Switch Copy	32
4.6.3 Data Dump/Load	33
4.6.4 Factory Reset	33
5. CABLES	34
5.1 XPDL	34
5.2 Function Switches	34
6. MIDI IN SPECIFICATION	35
6.1 Preset Changes	35
6.2 Individual IA Switch Controls	35
7. CONNECTION EXAMPLES	36

1. INTRODUCTION

Thank you for purchasing the Musicom Lab EFX-LE II Audio Controller.

The EFX-LE II Audio Controller is the ultimate floor-based switching system. It is a compact, easy to use, has 7 fully programmable loops, 2 function switches and a MIDI foot controller.

The EFX-LE II Audio Controller has 640 memory locations, configured as 160 banks of 4 presets, plus a global preset. It can transmit 12 MIDI messages (Program and Control Change and Note) when a preset is changed. Also, it can transmit 4 MIDI messages when the switches assigned to the page are pressed. One continuous controller port (XPDL) is included and can be programmed with a designated MIDI channel and controller number.

The EFX-LE II Audio Controller's loops can be changed the order, connected in parallel. It has two mixers/volume-contorllers, allowing you to store volume values for each preset.

The EFX-LE II Audio Controller has two outputs, OUT-L and OUT-R, can be used as stereo outputs, or as an A/B/Y switch for a mono guitar signal.

The EFX-LE II Audio Controller has two low-noise, high quality buffers to prevent the loss of guitar signal. Each buffer can be bypassed/engaged per each preset.

1.1 Main Features

- 7 audio loops. 4 mono loops, 2 stereo loops and 1 volume loop.
Volume Loop can be engaged/bypassed by IA switch or as parts of a preset.
- 2 stereo loops are stereo capable using TRS jacks.
- Changeable loop order per each preset.
- 2 buffers. Input buffer and Movable buffer.
Movable buffer can be placed anywhere in your signal path.
Each buffer can be enabled/disabled by IA switch or as parts of a preset.
- 2 internal mixers/volume-controllers.
Mixers also are used for Carry Over between presets, even with your analog delay or reverb.
2 volume values can be stored for each preset.
- 2 function switches via one TRS jack. You can control the switching functions of your amp.
- 640 presets (160 banks x 4 presets) and 1 global preset.
- Switches can be assigned to the user's preference.
- Create up to 480 songs.
- Organize the 480 Songs into 60 sets of 48 songs.
- Clickless function for reducing popping noise.
- ISO OUT that prevent to occur ground hum noise and phase issue.
- Transmits 12 MIDI (PC, CC and Note) messages, when a preset is changed.
Transmits 4 MIDI (PC, CC and Note) messages when the switches assigned to pages are pressed.
- Transmits MIDI Timing Clock and synchronizes with Function Switch1/2.
Tap tempo for both MIDI-compatible pedals and any pedals that have external tap input jacks.
BPM can be stored in each bank preset and song preset.
- Easily copy presets, songs, sets and switches.
- 2 Lines x 16 Characters LCD display that can display preset/song titles and other status.

1.2 Specifications

- Buffer Input Impedance 1 M Ω
- Buffer Output Impedance 100 Ω
- Mixer/Volume-Controller Input Impedance..... 44 k Ω
- Mixer/Volume-Controller Output Impedance.... 100 Ω
- Nominal Audio Signal Level -10 dBu
- Maximum Audio Signal Level +18 dBu
- Current Draw 200 mA (DC9V Center Negative)
- Dimensions 320 mm(W) x 96 mm(D) x 68 mm(H)
12.6 inches(W) x 3.8 inches(D) x 2.7 inches(H)
- Weight 1,090 g / 2.4 lbs

1.3 Block Diagram

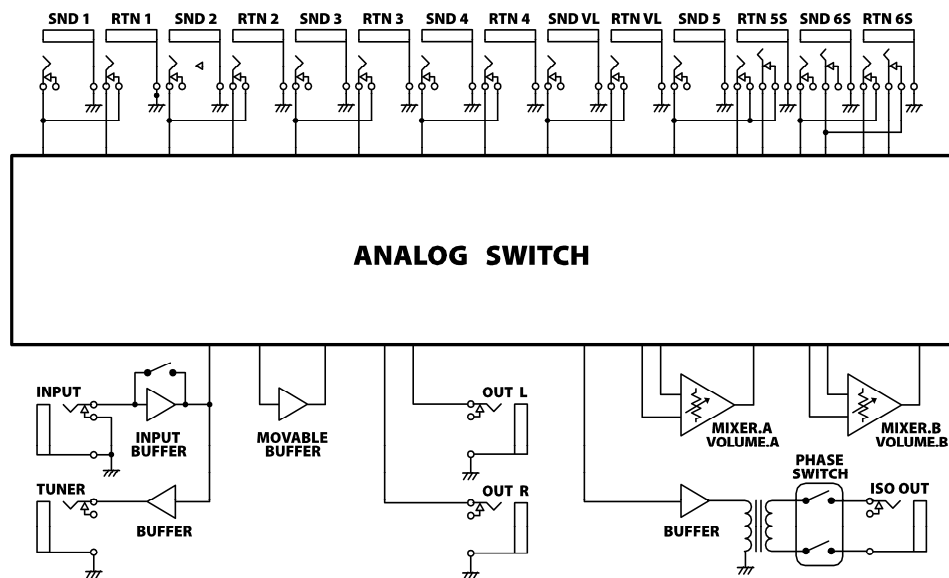

1.4 Front Panel

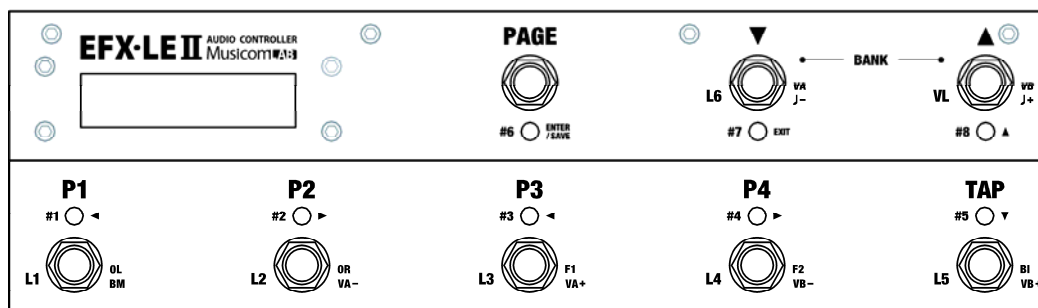

P1 through P4 switches

On the Page 1, these switches are used to recall the corresponding preset. When on other pages, pressing these switch turn on/off the corresponding effect loops, function switches, outputs, buffers, etc.

TAP switch

TAP can be synchronized with **MIDI Time Clock(MTC)** or Function Switches(**F1/F2**). The Function Switches support for devices that only have an analog tap tempo input. Also you can select whether or not to send the **MTC**.

Tapping the **TAP** switch will change the **MTC** or **F1/F2** rate to the tempo of your taps.

At this time, the **Global.BPM** will be changed to the tempo of your taps.

The **Global.BPM** is changed by tapping the **TAP** switch is applied to the current bank or song. In other words, the **Preset.BPM** stored in the current bank or song is ignored.

When the EFX-LE II powers up, the **Global.BPM is 120**.

PAGE switch

Pressing this switch puts the EFX-LE II into the other page, where you can turn individual loops on and off, and store their settings to presets.

On the page 1, pressing & holding this switch for 1 second will execute/cancel the **MUTE** function.

On other pages, pressing & holding this switch for 1 second will store the edit and return to the page 1.

Factory setting provides up to 4 pages, and up to 6 pages can be used depending on the user's preference.

BANK▲ & BANK▼ switches

The 640 presets in the EFX-LE II are arranged in banks of 4, and these buttons allow you to select which bank of 4 you'd like to access. Pressing this switch in Preset mode increments/decrements the bank number.

Pressing the **BANK▼** switch while pressing the **BANK▲** switch increases the bank number by 10.

Conversely, Pressing the **BANK▲** switch while pressing the **BANK▼** switch decreases the bank number by 10.

LCD Display

```

a b c d e f g h i j k l m n o p
1 B001 Preset 001
2 1.1 123456ABLR12

```

- Line 1 - a to d indicate a bank number.
- Line 1 - e to p indicate the preset title of the current preset.
- Line 2 - a indicates a preset number within the current bank.
- Line 2 - c indicates a page number within the current preset.
- Line 2 - e to j indicate which of the 6 audio loops are currently active.
- Line 2 - k and l indicate which of the two volume controllers are active.
- Line 2 - m and n indicate which of the two audio outputs are active.
- Line 2 - o and p indicate which of the 2 function switches are currently active.

1.5 Rear Panel

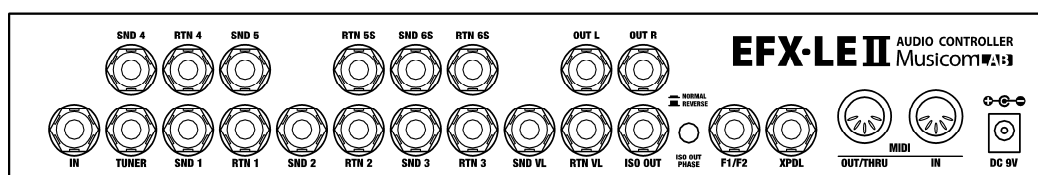

IN Jack

This is the main input jack where your guitar plugs in.

SND 1-4, RTN 1-4 Jacks

These jacks provide mono-send mono-return effect loops. **SND 1-4** send signals to effect pedals. **RTN 1-4** receive signals from effect pedals. Connect the **SND 1-4** jacks to the **INPUT** jack of each effect pedal, and connect the **OUTPUT** jack of each effect pedal to the **RTN 1-4** jacks.

SND 5, RTN 5S Jacks

These jacks provide a mono-send stereo-return effect loop. **RTN 5S** jack is stereo capable using TRS connectors. If the last stage of the chain is the stereo-send effect loop or the output, the signal is output in stereo. If the last effect loop in the chain is the mono-send effect loop, only the signal received at the tip conductor of the **RTN 5S** jack is output.

SND 6S, RTN 6S Jacks

These jacks provide a stereo-send stereo-return effect loop. These jacks are stereo capable using TRS connectors. If the last stage of the chain is the stereo-send effect loop or the output, the signal is output in stereo. If the last effect loop in the chain is the mono-send effect loop, only the signal received at the tip conductor of the **RTN 6S** jack is output.

SND VL, RTN VL Jacks

These jacks are for connecting a volume pedal. You can also use these jacks as send/return for a preamp.

OUT L, OUT R Jacks

These are the output jacks. **OUT-L** and **OUT-R** can be turned on/off independently. If the last stage of the chain is the mono output, the **OUT-L** signal is split up in to the **OUT-R**.

TUNER Jack

This jack is for connecting an external tuner.

F1/F2 Jack

Latched or momentary function switch jack for amplifier channel switching or on/off controlling of reverb.

TRS plug's Tip : **F1** TRS plug's Ring : **F2** TRS plug's Sleeve : Common ground for **F1/F2**

XPDL Jack

An expression pedal or 2 external foot-switches (normally Open Type) can be connected to this jack using a 1/4" TRS cable. The TRS cable must be connected before supplying power to the EFX-LE II. Refer to the **5.1 XPDL** on the page 34 of the manual for cabling.

ISO OUT Jack and ISO PHASE Switch

There is an isolation transformer before the **ISO OUT** jack. The isolation transformer may help reduce hum that can occur when using two amps or 4CM. If the **ISO OUT** are used, **ISO OUT** can also be inverted the phase by pressing the **ISO OUT PHASE** switch. Refer to the **ISO-OUT SOURCE** on the page 30 of the manual.

MIDI IN, MIDI OUT/THRU Connector

MIDI IN connector receives MIDI signals from an external MIDI device. **MIDI OUT/THRU** connector is used to feed MIDI signals to external MIDI devices. When the operation mode of **MIDI OUT/THRU** has been set to 'THRU', MIDI signals received at **MIDI IN** pass through the EFX-LE II without any changes.

DC9V Power Connector

This is the main power input for the EFX-LE II. The EFX-LE II requires a DC9V power supply.

The current draw is approximately **200mA** at **DC9V (Center Negative)**.

2. BASIC OPERATION

2.1 Initial Power Up

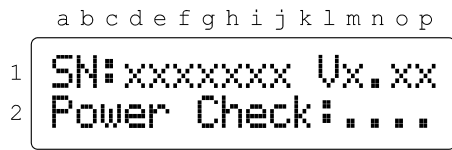

- Line 1 - d to j indicate the serial number of your unit.
- Line 1 - m to p indicate the firmware version of your unit.
- Line 2 - m to p indicate the power test results.
OK : Input Voltage is 8.4V~9.6V.
Low : Input Voltage is under 8.4V.
High : Input Voltage is over 9.6V.

The EFX-LE II requires a **DC9V** power supply.

When you power up the EFX-LE II, the LCD display will show the serial number, firmware and power test results. And then the Page 1 of **Bank 01**(or **Song 01**), **Preset 1** is selected.

- * When power is applied, power is supplied/blocked twice to the analog circuit for power testing.
 At this point, two click sounds are output. If possible, connect the EFX-LE II to the amplifier after a power test.

2.2 Page 1



- Line 1 - b to d indicate a bank number.
- Line 1 - e to p indicate the preset title of the current preset.
- Line 2 - a indicates a preset number within the current bank.
- Line 2 - c indicates a page number within the current preset.
- Line 2 - e to p indicate which of the IA switches are currently active.

The EFX-LE II has 640 presets and 1 global preset that you can choose from, and they're arranged in banks of four. When the EFX-LE II powers up, it selects **Page 1, Preset 1** and **Bank 1**.

Press/hold **BANK▼** or **BANK▲** switch to shift other banks, pressing one of the four switches (**P1 - P4**) selects a preset in the new bank.

- ① Press/hold the **BANK▼** or **BANK▲** switch to scroll through the 160 available banks.
- ② The bank number on the LCD display will blink and the LEDs above **P1 - P4** switches will turn off.
- ③ The preset is selected via pressing any switches from **P1** through **P4**.
- ④ The bank number on the LCD display will stop blinking and the LED above the switch will be turned on in blue.

For example: to select the second preset of bank 3, press the **BANK▼** or **BANK▲** switch until the bank number **003** is shown on the LCD display. And then press the **P2** switch.

The **GLOBAL PRESET** is a preset with all the capabilities of **PRESET 1** through **4**, but is the same for all banks. Pressing the switch of a preset that is already on selects the global preset and will cause the LED above the switch to be turned off. To enable/disable the Global Preset, refer to the **PST 2nd PRESS** on the page 31 of the manual.

SW #1	SW #2	SW #3	SW #4	SW #5	SW #6	SW #7	SW #8
Preset 1	Preset 2	Preset 3	Preset 4	Tap Tempo(*)	Page Up /Mute(**)	Bank Down	Bank Up

* The **Global.BPM** changed by tapping the **TAP** switch is applied to the current bank or song. In other words, the **Preset.BPM** stored in the current bank or song is ignored.

** Pressing/holding the **#6** switch for 1 second will mute the guitar signal.

Pressing/holding the **#6** switch for 1 second or press any switches from **P1** through **P4** switch will cancel the **MUTE** function.

2.3 Page 2

This page allows you to turn each of the audio loops on or off individually. On the **Page 1**, pressing the **PAGE** switch brings you to the **Page 2**. To left bottom of the each switch, there is a label reading **L1** through **VL**.

The following is the assignment of each switch on the **Page 2**.

SW #1	SW #2	SW #3	SW #4	SW #5	SW #6	SW #7	SW #8
Loop 1	Loop 2	Loop 3	Loop 4	Loop 5	Page Up /Save(*)	Loop 6	Volume Loop

* Pressing/holding the **#6** switch for 1 second will store the edit and return to the **Page 1**.

For the other side, pressing the **#6** switch will move to the **Page 3**.

If there is a change in the combination of IA switches, the preset number of the LCD display will blink.

2.4 Page 3

This page allows you to control 2 function switches, outputs, volume controllers and input buffer individually. On the **Page 2**, pressing the **PAGE** switch brings you to the **Page 3**. To first right bottom of the each switch, there is a label what the switch does on the **Page 3**.

The following is the assignment of each switch on the **Page 3**.

SW #1	SW #2	SW #3	SW #4	SW #5	SW #6	SW #7	SW #8
Output Left	Output Right	Function Switch 1	Function Switch 2	Input Buffer	Page Up /Save(*)	Volume A (**)	Volume B (**)

* Pressing/holding the **#6** switch for 1 second will store the edit and return to the **Page 1**.

For the other side, pressing the **#6** switch will move to the **Page 4**.

** Volume A/B cannot be switched on/off when used as a parallel connection or carry over function.

If there is a change in the combination of IA switches, the preset number of the LCD display will blink.

2.5 Page 4

This page allows you to control the movable buffer and increase/decrease **Preset.BPM** and **Volume Values** individually. On the **Page 3**, pressing the **PAGE** switch brings you to the **Page 4**. To second right bottom of the each switch, there is a label what the switch does on the **Page 4**.

The following is the assignment of each switch on the **Page 4**.

SW #1	SW #2	SW #3	SW #4	SW #5	SW #6	SW #7	SW #8
Movable Buffer	Decrease Volume A	Increase Volume A	Decrease Volume B	Increase Volume B	Page Up /Save(*)	Decrease Preset BPM	Increase Preset BPM

* Pressing/holding the **#6** switch for 1 second will store the edit and return to the **Page 1**.

For the other side, pressing the **#6** switch will move to the **Page 1**.

If there is a change in the combination of IA switches, the preset number of the LCD display will blink.

3. SONG / SET MODE

The Song operating mode allows access to the EFX-LE II's 480 songs. A Song is a group of 4 presets that are selected for use in a particular song. Each preset in a song can be chosen from any of the 640 presets. The Set operating mode allows up to 48 songs of the EFX-LE II's 480 songs to be arranged in any order to create a set. The EFX-LE II can support 60 different sets.

When you are in the **SONG** and **SET** mode, the **BANK▼** or **BANK▲** Switches move from song to song instead of moving from bank to bank.

Refer to the **OPERATE MODE** on the page 31 of the manual.

3.1 SONG Mode

	a	b	c	d	e	f	g	h	i	j	k	l	m	n	o	p
1	S	0	0	1	S	o	n	g	0	0	1					
2	1	.	1	L	R

- Line 1 - b to d indicate a song number.
- Line 1 - e to p indicate the song title of the current song.
- Line 2 - a indicates a preset number within the current song.
- Line 2 - c indicates a page number within the current preset.
- Line 2 - e to p indicate which of the IA switches are currently active.

- ① Press/hold the **BANK▼** or **BANK▲** switch to scroll through the 480 available songs.
- ② The song number on the LCD display will blink and show the song title.
The LEDs above **P1 - P4** switches will turn off.
- ③ The preset is selected via pressing any switches from **P1** through **P4**.
- ④ The song number on the LCD display will stop blinking and show the preset title for 2 seconds and then show the song title. The LED above the switch will be turned on in blue.

3.2 SET Mode

	a	b	c	d	e	f	g	h	i	j	k	l	m	n	o	p
1	S	0	1	S	o	n	g	0	0	1						
2	1	.	1	L	R

- Line 1 - b and c indicate a song number.
- Line 1 - e to p indicate the song title of the current song.
- Line 2 - a indicates a preset number within the current song.
- Line 2 - c indicates a page number within the current preset.
- Line 2 - e to p indicate which of the IA switches are currently active.

- ① Press/hold the **BANK▼** or **BANK▲** switch to scroll through the 48 available songs.
- ② The song number on the LCD display will blink and show the song title.
The LEDs above **P1 - P4** switches will turn off.
- ③ The preset is selected via pressing any switches from **P1** through **P4**.
- ④ The song number on the LCD display will stop blinking and show the preset title for 2 seconds and then show the song title. The LED above the switch will be turned on in blue.

4. SETUP MODE

To enter the **SETUP** mode, press the **#6(PAGE)** and **#8(BNAK UP)** switches simultaneously on the **Page 1**. The LCD display will show the following picture.

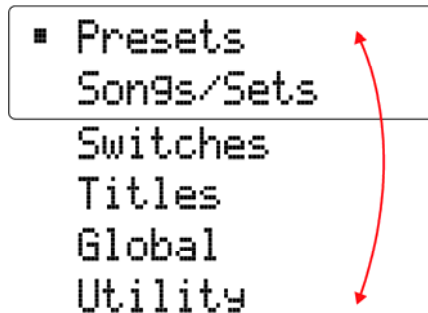

SW #5 & SW #8	Moving a Setup menu.
SW #6	Entering the selected menu.
SW #7	Exiting the Setup mode.

4.1 PRESETS MENU

The **Presets** menu consists of two sub-menus (**MIDI/Volume** and **Routing**).

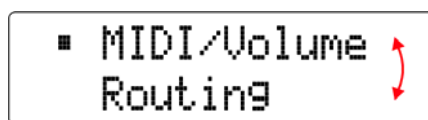

SW #5 & SW #8	Moving a Presets menu.
SW #6	Entering the selected menu.
SW #7	Rerutning to the Setup menu.

4.1.1 MIDI / VOLUME

The **MIDI/Volume** menu allows assigning 12 MIDI messages (PC, CC and Note), **Preset.BPM**, two **Volume** values and determining how the expression port(**XPDL**) will function when used function in the preset.

Editing MIDI.01 ~ MIDI.12

```

a b c d e f g h i j k l m n o p
1 PST.001 MIDI.01
2 = PC C:01 #:001*

```

- Line 1 - e to g indicate the preset number that is going to be created/modified. (**001~640** or **GLB**)
- Line 1 - o and p indicate the MIDI message that is going to be created/modified. (**01~12**)
- Line 2 - b to e indicate the type of MIDI message. (**None, PC, CC, NT**)
None : No MIDI **PC** : MIDI Program Change
CC : MIDI Control Change **NT** : MIDI Note On
- Line 2 - h and i indicate the MIDI Program Change channel. (**01~16**)
- Line 2 - m to o indicate the MIDI Program Change number. (**001~128**)
- Line 2 - p indicates that a next page exists

```

a b c d e f g h i j k l m n o p
1 PST.001 MIDI.01
2 * MB:000 LB:OFF

```

- Line 2 - a indicates that a previous page exists
- Line 2 - f to h indicate the MIDI Bank Change number, **MSB**
- Line 2 - m to p indicate the MIDI Bank Change number, **LSB** (**000~127** or **OFF**)

* The above two LCD screens show when the **PC** (Program Change) is selected.

	a b c d e f g h i j k l m n o p	
1	PST.001 MIDI.01	<ul style="list-style-type: none"> Line 2 - b to e indicate the type of MIDI message. (None, PC, CC, NT) None : No MIDI PC : MIDI Program Change CC : MIDI Control Change NT : MIDI Note On Line 2 - h and i indicate a MIDI Control Change channel. (01-16) Line 2 - m to o indicate a MIDI Controller number. (000-127)
2	= CC C:01 #:000*	

	a b c d e f g h i j k l m n o p	
1	PST.001 MIDI.01	<ul style="list-style-type: none"> Line 2 - f to h indicate the MIDI Controller value. (000-127)
2	* UL:000	

* The above two LCD screens show when the **CC** (Control Change) is selected.

	a b c d e f g h i j k l m n o p	
1	PST.001 MIDI.01	<ul style="list-style-type: none"> Line 2 - b to e indicate the type of MIDI message.(None, PC, CC, NT) None : No MIDI PC : MIDI Program Change CC : MIDI Control Change NT : MIDI Note On Line 2 - h and i indicate the MIDI Note On channel. (01-16) Line 2 - m to o indicate the MIDI Note(Key) number. (000-127)
2	= NT C:01 #:000*	

	a b c d e f g h i j k l m n o p	
1	PST.001 MIDI.01	<ul style="list-style-type: none"> Line 2 - f to h indicate the MIDI velocity. (000-127)
2	* UL:000	

* The above two LCD screens show when the **NT** (Note On) is selected.

SW #1 & SW #2	Moving the selected blinking area.
SW #5 & SW #8	Blinking at the Line 1 - a to g : Increasing/decreasing a preset number. Blinking at the Line 1 - j to p : Scrolling MIDI.01-MIDI.12 , XPDL , BPM and Volume.A/B . Blinking at the Line 2 - b to e : Scrolling PC , CC , NT and None . Blinking at the other area : Increasing/decreasing a value.
SW #6	Storing any changes made while in this menu.
SW #7	Rerutning to the Presets menu.

Editing XPDL

	a b c d e f g h i j k l m n o p	
1	PST.001 XPDL	<ul style="list-style-type: none"> Line 1 - e to g indicate the preset number that is going to be created/modified. (001-640 or GLB) Line 1 - m ~ p indicate that XPDL is selected. Line 2 - c to e indicate whether the XPDL is configured as Preset(PST) or Global (GLB).
2	= GLB	

* The above LCD screen shows when the **GLB** (Global) is selected.
Refer to the **XPDL** on the page 28 of the manual.

a b c d e f g h i j k l m n o p

```

1 PST.001      XPDL
2 =PST C:01  #:OFF*

```

- Line 2 - b to d indicate whether the **XPDL** is configured as Preset(**PST**) or Global (**GLB**).
- Line 2 - h and i indicate the MIDI Control Change channel. (**01-16**)
- Line 2 - m to o indicate the MIDI Controller number. (**000-127**)
- Line 2 - p indicates that a next page exists

a b c d e f g h i j k l m n o p

```

1 PST.001      XPDL
2 * BG:OFF MX:127*

```

- Line 2 - a indicates that a previous page exists
- Line 2 - f to h indicate indicate the initial **XPDL** value that the expression pedal port will transmit when the preset is selected.
- Line 2 - m to o indicate indicate the highest **XPDL** value that the expression pedal port can transmit when its pedal is moved.
- Line 2 - p indicates that a next page exists

a b c d e f g h i j k l m n o p

```

1 PST.001      XPDL
2 * MN:000

```

- Line 2 - a indicates that a previous page exists
- Line 2 - f to h indicate indicate the lowest **XPDL** value that the expression pedal port can transmit when its pedal is moved.

* The above three LCD screens show when the **PST** (Preset) is selected.

SW #1 & SW #2	Moving the selected blinking area.
SW #5 & SW #8	Blinking at the Line 1 - a to g : Increasing/decreasing a preset number. Blinking at the Line 1 - j to p : Scrolling MIDI.01-MIDI.12 , XPDL , BPM and Volume.A/B . Blinking at the Line 2 - b to e : Switching GLB and PST . Blinking at the other area : Increasing/decreasing a value.
SW #6	Storing any changes made while in this menu.
SW #7	Rerutning to the Presets menu.

Editing BPM

a b c d e f g h i j k l m n o p

```

1 PST.001      ↓ BPM
2              =      120

```

- Line 1 - e to g indicate the preset number that is going to be created/ modified. (**001-640** or **GLB**)
- Line 1 - l to p indicate that **Preset.BPM** is selected.
- Line 2 - n to p indicate indicate the **BPM** of the current preset. (**40-209** or **GLB**)

SW #1 & SW #2	Moving the selected blinking area.
SW #5 & SW #8	Blinking at the Line 1 - a to g : Increasing/decreasing a preset number. Blinking at the Line 1 - l to p : Scrolling MIDI.01-MIDI.12 , XPDL , BPM and Volume.A/B . Blinking at the Line 2 - n to p : Scrolling a Preset.BPM value.
SW #6	Storing any changes made while in this menu.
SW #7	Returning to the Presets menu.

Editing Volume.A & Volume.B

```

a b c d e f g h i j k l m n o p
1 PST.001 Volume.A
2           = 0.0dB
  
```

- Line 1 - e to g indicate the preset number that is going to be created/modified. (**001~640** or **GLB**)
- Line 1 - i to p indicate that **Volume.A** or **Volume.B** is selected.
- Line 2 - j to p indicate the volume value of the current preset. (**-48.5dB ~ +15.0dB**)

SW #1 & SW #2	Moving the selected blinking area.
SW #5 & SW #8	Blinking at the Line 1 - a to g : Increasing/decreasing a preset number. Blinking at the Line 1 - i to p : Scrolling MIDI.01~MIDI.12 , XPDL , BPM and Volume.A/B . Blinking at the Line 2 - j to p : Scrolling a Volume value .
SW #6	Storing any changes made while in this menu.
SW #7	Rerutning to the Presets menu.

4.1.2 ROUTING

The **Routing** menu allows changing loop structure you can make the following settings.

- Change the connection order of effect loops
- Create a parallel connection
- Create a split connection
- Specify Carry Over

The EFX-LE II has two internal mixers. By using these internal mixers, you can connect loops in parallel, use the Carry Over function and set the volume each preset.

- * Two mixer(**A**, **B** or **S**) are used for parallel connections, Carry Over functions and volume control.
- * For the mono/stereo returns of effect loops 5 and 6, Refer to the **LOOP5/6 RETURN** and **LOOP6 SEND** on the page 29 of the manual.
- * In order to use the Carrie Over function correctly, it is necessary to set the Carrie Over on both the current preset and the next selected preset.

```

a b c d e f g h i j k l m n o p
1 PST.001
2 I-1-2-3-4-M-U-5-
  
```

SIGNAL FLOW →

```

a b c d e f g h i j k l m n o p
1 -3-4-M-U-5-6-B-R
2 -3-4-M-U-5-6-A-L
  
```

SIGNAL FLOW →

1-6	Loop Number
ī-ē	A loop for which Carry Over is specified
U	Volume Loop
M	Movable Buffer (BM)
A/B/S	Mixers/ Volume Controllers
-	Mono connection
=	Stereo connection

- Line 1 - e to g indicate the preset number that you want to edit.

* **A** and **B** are the Mono Mixers/Volume-Contollers.

S is the Stereo Mixer/Volume-Contoller.

A and **B** can be combined into **S**, and **S** can be divided into **A** and **B**

SW #1 & SW #2	Moving the cursor.
SW #3 & SW #4	When the cursor is at the loop number or volume A/B/S : Moving the selected loop to the left/right. When the cursor is at the signal line : SW #3 : Creating/deleting a parallel connection. SW #4 : Creating/deleting a signal split.
SW #5 & SW #8	When the cursor is at the I : Increasing/decreasing a preset number When the cursor is at the loop numbers or volume A/B/S : SW #5 : Moving the selected loop to the up/down. SW #8 : When the cursor is at the loop number : Creating/deleting a Carry Over. When the cursor is at the volume A/B/S : Changing A-B to S or S to A-B.
SW #6	Storing any changes made while in this menu.
SW #7	Returning to the Presets menu.

Changing the Effect Loop Connection Order

Example : Change the order of effect loops 3 and 4.

- Use the **#1** or **#2** switch to move the cursor to loop 3.
- Press **#4** switch to move the loop 3.

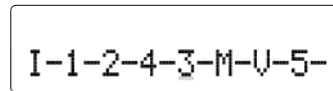
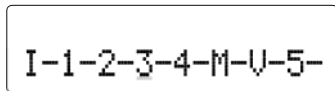

- Press the **#6** switch to store this edit.

Making a parallel Connection

Example : Connect effect loops 5 and 6 in parallel.

- Press the **#1** or **#2** switch to move the cursor to the **A**.
- Press **#3** switch to move to next to the loop 6.

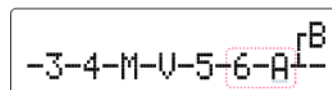
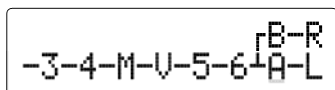

- Press the **#1** switch to move the cursor before loop 6.
- Press **#3** switch to specify the parallel connection.

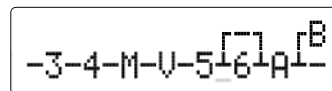
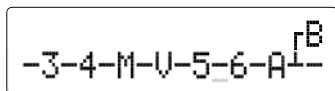

- Press the **#1** switch to move the cursor to the loop 5.
- Press **#4** switch to move the loop 5 into the parallel connection.

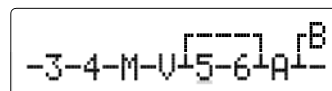
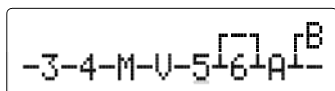

- Press the **#5** switch to move the loop 5 to the upper line.

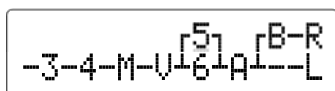

Specify Carry Over

Example : Specify Carry Over for effect loop 6.

- ① Press the **#1** or **#2** switch to move the cursor to the **A**.

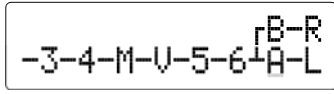

- ② Press **#3** switch to move to next to the loop 6.

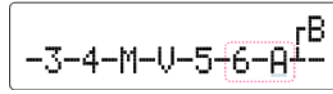

- ③ Press the **#1** switch to move the cursor to the loop6.

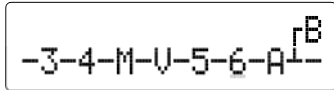

- ④ Press **#8** switch to to specify the Carry Over.

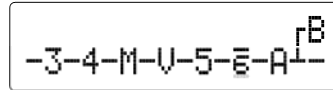

Making a Split Connection

Example : Signal split before the loop 5.

- ① Press the **#1** or **#2** switch to move the cursor to the **B**.



- ② Press **#5** switch to move the **B** to the lower line.

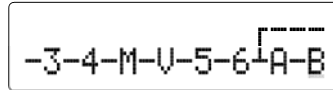

- ③ Press the **#1** switch to move the cursor before the **A**.

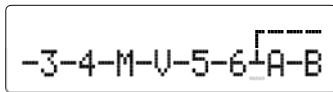

- ④ Press **#4** switch to delete the split connection.

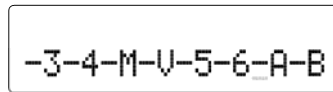

- ⑤ Press the **#1** switch to move the cursor before the loop 5.

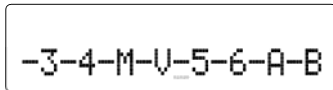

- ⑥ Press **#4** switch to create the split connection.

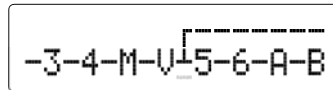

- ⑦ Press the **#2** switch to move the cursor to the loop 6.

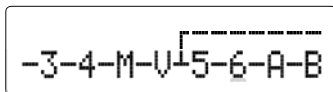

- ⑧ Press **#5** switch to move the loop6 to the upper line.

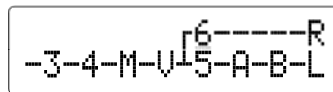

- ⑨ Press the **#2** switch to move the cursor to the **B**.

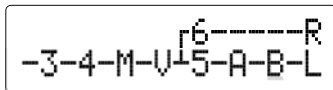

- ⑩ Press **#5** switch to move the **B** to the upper line.

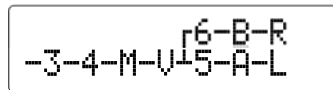

Combining into S & deviding into A/B

- ① Make **A-B** or **B-A** and place the cursor in the preceding character.

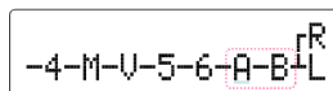

- ② Press **#8** switch to combine in to the **S**.

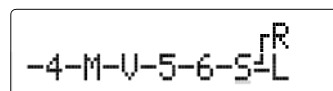

* The division process is the reverse of the above-performed process.

4.2 SONGS/SETS MENU

The **Songs/Sets** menu allows for the EFX-LE II's regular presets to be organized in a custom bank to create a song (or custom bank of presets). Multiple songs can then be arranged in a bank in order to create a set.

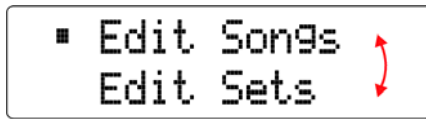

SW #5 & SW #8	Moving the selected blinking menu.
SW #6	Entering the selected menu.
SW #7	Rerutning to the Setup menu.

4.2.1 EDIT SONGS

The sub-menu allows you to create a song (custom bank of presets) by assigning 4 presets. Each song contains 4 presets. The EFX-LE II can support 480 songs.

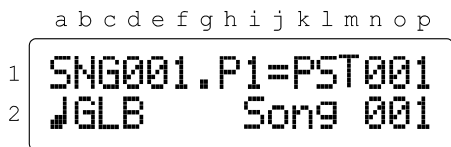

- Line 1 - d to f indicate a song number. (**001-480**)
- Line 1 - i indicates a preset within the song that is going to be created/edited.
- Line 1 - n to p indicate the preset number that the original preset is located in. (**001-640**)
- Line 2 - b to d indicates the BPM of the song preset (**40-209**, or **GLB**).
- Line 2 - e to p indicate the song or preset title.

SW #1 & SW #2	Moving the selected blinking area.
SW #5 & SW #8	Blinking at the Line 1 - a to f : Increasing/decreasing a song number. Blinking at the Line 1 - h and i : Increasing/decreasing a preset number in the song. Blinking at the Line 1 - k to p : Increasing/decreasing a preset number. Blinking at the Line 2 - a to d : Increasing/decreasing the BPM value of the song preset.
SW #6	Storing any changes made while in this menu.
SW #7	Rerutning to the Songs/Sets menu.

4.2.1 EDIT SETS

The sub-menu allows songs to be arranged in a bank order to create set. The EFX-LE II can support 60 sets, they can be accessed via **SET01 - SET60** Operating Mode.

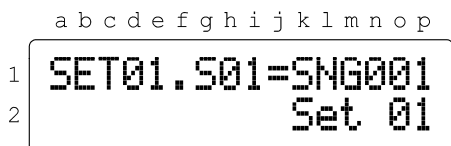

- Line 1 - d and e indicate a set number. (**01-60**)
- Line 1 - h and i indicate a song number within the set. (**01-48**)
- Line 1 - n to p indicate the original song number to be used in the set. (**001-480**)
- Line 2 - e to p indicate the set or song title.

SW #1 & SW #2	Moving the selected blinking area.
SW #5 & SW #8	Blinking at the Line 1 - a to e : Increasing/decreasing a set number. Blinking at the Line 1 - g to i : Increasing/decreasing a song number within the set. Blinking at the Line 1 - k to p : Increasing/decreasing a original song number.
SW #6	Storing any changes made while in this menu.
SW #7	Rerutning to the Songs.Sets menu.

4.3 SWITCHES MENU

The **Switches** menu allows you to set the functionality of the switch assigned to each page. You can set a completely different function on the switch for up to 6 pages. By factory default, there are four pages, and for each switch function, refer to the table below.

	SW #1	SW #2	SW #3	SW #4	SW #5	SW #6	SW #7	SW #8	EX #1	EX #2
Page 1	Preset 1	Preset 2	Preset 3	Preset 4	Tap Tempo	Page Up /Save	Bank Down	Bank Up	None	None
Page 2	Loop 1	Loop 2	Loop 3	Loop 4	Loop 5	Page Up /Store	Loop 6	Volume Loop	None	None
Page 3	Ouput Left	Ouput Right	Function Switch 1	Function Switch 2	Input Buffer	Page Up /Store	Volume.A	Volume.B	None	None
Page 4	Movable Buffer	Volume.A Decrease	Volume.A Increase	Volume.B Decrease	Volume.B Increase	Page Up /Store	BPM Decrease	BPM Increase	None	None

* **EX #1** and **EX #2** means when two external footswitches are connected to the **XPDL** jack. Refer to the **5.1 XPDL** on the page 33 of the manual for cabling.

Each switch can be assigned one of the ones listed in the table below.

None	No function is assigned to the switch.
Preset	The preset selection function is assigned to the switch.
IA	The Intent Access switch function which turns certain functions on or off is assigned to the switch.
TapTempo	The function of changing the Global.BPM value is assigned by tapping this switch.
PG+/Mute	The Page Up function is assigned to the switch. Pressing/Holding the switch for 1 second turns the Mute function on or off.
PG-/Mute	The Page Down function is assigned to the switch. Pressing/Holding the switch for 1 second turns the Mute function on or off.
PG+/Save	The Page Up function is assigned to the switch. Pressing/Holding the switch for 1 second saves the combination of IA switches.
PG-/Save	The Page Down function is assigned to the switch. Pressing/Holding the switch for 1 second saves the combination of IA switches.
Bank+	The Bank Up function is assigned to the switch. (*)
Bank-	The Bank Down function is assigned to the switch. (*)
Vol.A+	The function of increasing the Volume.A value by 0.5dB is assigned to the switch. (*)
Vol.A-	The function of decreasing the Volume.A value by 0.5dB is assigned to the switch. (*)
Vol.B+	The function of increasing the Volume.B value by 0.5dB is assigned to the switch. (*)
Vol.B-	The function of decreasing the Volume.B value by 0.5dB is assigned to the switch. (*)
BPM+	The function of increasing the Preset.BPM or Song.BPM value is assigned to the switch. (*)
BPM-	The function of decreasing the Preset.BPM or Song.BPM value is assigned to the switch. (*)

(*) Pressing the **+** switch while holding down the **-** switch decreases the value by 10.

Conversely, pressing the **-** switch while holding down the **+** switch increases the value by 10.

You can edit switch assignments using the switch functions below.

SW #1 & SW #2	Moving the selected blinking area.
SW #5 & SW #8	Increasing/decreasing the selected item.
SW #6	Storing any changes made while in this menu.
SW #7	Returning to the Setup menu.

4.3.1 Assign as PRESET Switch

This page allows you to set the preset number, LED color, and four MIDI messages.

```

a b c d e f g h i j k l m n o p
1 PG1.SW1 SW.Type
2           =  Preset
  
```

- Line 1 - a to g indicate the switch that is going to be created/modified.
- Line 1 - i to p indicate the details that can be set when the switch is assigned to the preset switch.
(**Preset#**, **LedColor**, **MIDI.1~MIDI.4**)
- Line 2 - k to p indicate the switch that is assigned as the preset switch.

Preset #

A bank or song consists of 3 to 5 presets.

This page allows you to set the preset number to which the switch is used in the bank or song.

```

a b c d e f g h i j k l m n o p
1 PG1.SW1 Preset#
2           =  Preset1
  
```

- Line 2 - j to p indicate indicate the preset number to which the switch is used in the bank or song. (**Preset#1 ~ Preset#5**)

Refer to the **Preset/BnkSng** on the page 31 of the manual.

LED Color

This page allows you to set the LED color that turns on when the switch is pressed.

```

a b c d e f g h i j k l m n o p
1 PG1.SW1 LedColor
2           =  Blue
  
```

- Line 2 - k to p indicate the color of the LED that turn on.
(**None**, **Blue**, **Red** or **Purple**)

MIDI.1 ~ MIDI.4

EFX-LE II can send four MIDI messages (PC, CC and Note) when the switch is pressed.

```

a b c d e f g h i j k l m n o p
1 PG1.SW1 MIDI.1
2 =None
  
```

- Line 2 - b to e indicate the type of MIDI message. (**None**, **PC**, **CC**, **NT**)
None : No MIDI **PC** : MIDI Program Change
CC : MIDI Control Change **NT** : MIDI Note On

* The above LCD screen shows when the **None** is selected. **None** means no MIDI message is sent.

```

a b c d e f g h i j k l m n o p
1 PG1.SW1 MIDI.1
2 = PC      C:01 *
  
```

- Line 2 - c and d indicate the MIDI Program Change is selected.
- Line 2 - m and n indicate the MIDI Program Change channel. (**01~16**)
- Line 2 - p indicates that a next page exists

```

a b c d e f g h i j k l m n o p
1 PG1.SW1 MIDI.1
2 * N#:000
  
```

- Line 2 - a indicates that a previous page exists
- Line 2 - f to h indicate a MIDI Program Change number. (**001~128**)

* The above two LCD screens shows when the **PC** (Program Change) is selected.

a b c d e f g h i j k l m n o p

1	PG1.SW1	MIDI.1
2	= CC C:01	#:000*

- Line 2 - c and d indicate the MIDI Control Change is selected.
- Line 2 - h and i indicate the MIDI Control Change channel. (**01-16**)
- Line 2 - m to o indicate the MIDI Controller number. (**000-127**)
- Line 2 - p indicates that a next page exists

a b c d e f g h i j k l m n o p

1	PG1.SW1	MIDI.1
2	* NU:000	

- Line 2 - a indicates that a previous page exists
- Line 2 - f to h indicate the MIDI Controller value. (**000-127**)

* The above two LCD screens shows when the **CC** (Control Change) is selected.

a b c d e f g h i j k l m n o p

1	PG1.SW1	MIDI.1
2	= NT C:01	#:000*

- Line 2 - c and d indicate the MIDI Note On is selected.
- Line 2 - h and i indicate the MIDI Note On channel (**01-16**).
- Line 2 - m to o indicate the MIDI Note(Key) number (**000-127**).
- Line 2 - p indicates that a next page exists

a b c d e f g h i j k l m n o p

1	PG1.SW1	MIDI.1
2	* NU:000	

- Line 2 - a indicates that a previous page exists
- Line 2 - f to h indicate the MIDI Note(Key) velocity (**000-127**).

* The above two LCD screens shows when the **NT** (Note On) is selected.

4.3.2 Assign as IA Switch

This page allows you to set the IA attribute, LED color, four audio actions and four MIDI messages.

a b c d e f g h i j k l m n o p

1	PG2.SW1	SW.Type
2	=	IA

- Line 1 - a to g indicate the switch that is going to be created/modified.
- Line 1 - i to p indicate the details that can be set when the switch is assigned to the IA switch.
(**IA.Attrb, LedColor, Audio.1-Audio4, MIDI.1-MIDI.4**)
- Line 2 - k to p indicate indicate that the switch is assigned as the IA switch.

IA Attribute

You can set the following things in IA Attribute settings.

- Whether to latch or moment the switch response
- Whether or not IA On/OFF is linked to a preset
- Set two or more IA switches as a group (up to three groups per page)
- Enable the IA switch to be switched on or off via the external MIDI controller

a b c d e f g h i j k l m n o p

1	PG2.SW1	IA.Attrb
2	Sw.Func=	Latched

- Line 2 - a to g indicate the Switch Function is selected.
- Line 2 - i to p indicate the selected switch function.
(**Latched** or **Momentary**)

```

a b c d e f g h i j k l m n o p
1 PG2.SW1 IA.Attrb
2 Change =LINK/PST

```

- Line 2 - a to f indicate the Change is selected.
- Line 2 - i to p indicate the initial setting of the IA switch when the preset is changed.
- LINK/PST** : The initial value is linked with the IA value stored in the preset.
- CLR/PST** : The initial value is OFF.
- NC/PST** : The previous value is retained even if the preset is changed.

```

a b c d e f g h i j k l m n o p
1 PG2.SW1 IA.Attrb
2 Group = None

```

- Line 2 - a to e indicate the Group is selected.
 - Line 2 - k to p indicate the group to which the IA switch belongs. (**None, Group1~Group3**)
- If there are three IA switches in the same group, for example, selecting one IA switch will turn the other switches off.

```

a b c d e f g h i j k l m n o p
1 PG2.SW1 IA.Attrb
2 CC.Rcv = #050

```

- Line 2 - a to f indicate the CC.Rev is selected.
- Line 2 - m to p indicate the specific MIDI controller number that the IA switch can be turned on or off. (**None, #xxx**)
- **CC Number = 10 x Page Number + Switch Number + 39**

LED Color

This page allows you to set the LED color when the IA switch is on..

```

a b c d e f g h i j k l m n o p
1 PG2.SW1 LedColor
2 = Red

```

- Line 2 - k to p indicate indicate the color of the LED that turn on. (**None, Blue, Red or Purple**)

AUDIO.1 ~ AUDIO.4

EFX-LE II can perform up to four audio actions when the IA switch is on or off.

```

a b c d e f g h i j k l m n o p
1 PG2.SW1 Audio.1
2 = Loop.1 Normal

```

- Line 2 - b to h indicate the type of audio that is performing the action.
- Line 2 - j to p indicate the polarity of the audio action. (**Normal or Reverse**)
- **Available Audio Types**
None, Loop.1, Loop.2, Loop.3, Loop.4, Loop.5, Loop.6, Vol.Lp, Out.L, Out.R, In.Buf, Mov.Buf, Vol.A, Vol.B, Func.1, Func.2

MIDI.1 ~ MIDI.4

EFX-LE II can send four MIDI messages (PC, CC and Note) when the IA switch is on or off.

```

a b c d e f g h i j k l m n o p
1 PG2.SW1 MIDI.1
2 =None

```

- Line 2 - b to e indicate the type of MIDI message (**None, PC, CC, NT**).
None : No MIDI **PC** : MIDI Program Change
CC : MIDI Control Change **NT** : MIDI Note On

* The above LCD screen shows when the **None** is selected. **None** means no MIDI message is sent.

	a	b	c	d	e	f	g	h	i	j	k	l	m	n	o	p	
1	P	G	2	.	S	W	1	M	I	D	I	.	1				
2	=		P	C	C	:	0	1	*								

- Line 2 - c and d indicate the MIDI Program Change is selected.
- Line 2 - m and n indicate the MIDI Program Change channel (**01~16**).
- Line 2 - p indicates that a next page exists

	a	b	c	d	e	f	g	h	i	j	k	l	m	n	o	p	
1	P	G	2	.	S	W	1	M	I	D	I	.	1				
2	*		N	#	:	0	0	0	F	#	:	0	0	0			

- Line 2 - a indicates that a previous page exists
- Line 2 - f to h indicate the MIDI Program Change number transmitted when the IA switch is turned on. (**001~128**)
- Line 2 - n to p indicate the MIDI Program Change number transmitted when the IA switch is turned off. (**001~128**)

* The above two LCD screens shows when the **PC** (Program Change) is selected.

	a	b	c	d	e	f	g	h	i	j	k	l	m	n	o	p	
1	P	G	2	.	S	W	1	M	I	D	I	.	1				
2	=		C	C	:	0	1	#	:	0	0	0	*				

- Line 2 - c and d e indicate the MIDI Control Change is selected.
- Line 2 - h and i indicate the MIDI Control Change channel (**01~16**).
- Line 2 - m to o indicate the MIDI Controller number (**000~127**).

	a	b	c	d	e	f	g	h	i	j	k	l	m	n	o	p	
1	P	G	2	.	S	W	1	M	I	D	I	.	1				
2	*		N	V	:	0	0	0	F	V	:	0	0	0			

- Line 2 - f to h indicate the MIDI Controller value transmitted when the IA switch is turned on. (**000~127**)
- Line 2 - n to p indicate the MIDI Controller value transmitted when the IA switch is turned off. (**000~127**)

* The above two LCD screens shows when the **CC** (Control Change) is selected.

	a	b	c	d	e	f	g	h	i	j	k	l	m	n	o	p	
1	P	G	2	.	S	W	1	M	I	D	I	.	1				
2	=		N	T	:	0	1	#	:	0	0	0	*				

- Line 2 - c and d indicate the MIDI Note On is selected.
- Line 2 - h and i indicate the MIDI Note On channel (**01~16**).
- Line 2 - m to o indicate the MIDI Note(Key) number (**000~127**).

	a	b	c	d	e	f	g	h	i	j	k	l	m	n	o	p	
1	P	G	2	.	S	W	1	M	I	D	I	.	1				
2	*		N	V	:	0	0	0	F	V	:	0	0	0			

- Line 2 - f to h indicate the MIDI Note(Key) velocity transmitted when the IA switch is turned on. (**000~127**)
- Line 2 - f to h indicate the MIDI Note(Key) velocity transmitted when the IA switch is turned off. (**000~127**)

* The above two LCD screens shows when the **NT** (Note On) is selected.

4.3.3 Assign as TAP-TEMPO Switch

The Tap-Tempo switch is used to tap the switch to input the **Global.BPM**. This page allows you to set the LED color and four MIDI messages.

	a	b	c	d	e	f	g	h	i	j	k	l	m	n	o	p
1	P	G	1	.	S	W	5	S	W	.	T	y	p	e		
2	=		T	A	P	T	E	M	P	O						

- Line 1 - a to g indicate the switch that is going to be created/modified.
- Line 1 - i to p indicate the details that can be set when the switch is assigned to the tap tempo switch. (**LedColor, MIDI.1~MIDI.4**)
- Line 2 - i to p indicate indicate that the switch is assigned as the Tap Tempo switch.

The **LED color** and **MIDI.1~MIDI.4** can be set to the same procedures as the IA switch.

4.3.4 Assign as PAGE+/MUTE or PAGE-/MUTE Switch

When the switch is assigned as the **Page+/Mute** or **Page-/Mute**, it has two functions.

- Pressing this switch will increase/decrease the page.
- Pressing and holding this switch for 1 second will execute/cancel the **MUTE** function.

This page allows you to set the LED color, four audio actions and four MIDI messages. Audio actions and MIDI transmission are performed when the **MUTE** function is executed/cancelled.

	a b c d e f g h i j k l m n o p	
1	PG1.SW6 SW.Type	• Line 1 - a to g indicate the switch that is going to be created/modified.
2	=PG+/Mute	• Line 1 - i to p indicate the details that can be set when the switch is assigned to the Page+/Mute or Page-/Mute switch. (LedColor, Audio.1~Audio.4, MIDI.1~MIDI.4)
		• Line 2 - i to p indicate indicate that the switch is assigned as the Page+/Mute or Page-/Mute switch.

The **LED color**, **Audio.1~Audio.4** and **MIDI.1 ~ MIDI.4** can be set to the same procedures as the IA switch.

4.3.5 Assign as PAGE+/SAVE or PAGE-/SAVE Switch

When the switch is set to the Page+/Mute or Page-/Mute, it has two functions.

- Pressing this switch will increase/decrease the page.
- Pressing & holding this switch for 1 second will the combination of IA switches.

This page allows you to set the LED color and four MIDI messages. MIDI transmission are performed when the **Save** function is executed.

	a b c d e f g h i j k l m n o p	
1	PG2.SW6 SW.Type	• Line 1 - a to g indicate the switch that is going to be created/modified.
2	=PG+/Save	• Line 1 - i to p indicate the details that can be set when the switch is assigned to the Page+/Save or Page-/Save switch. (LedColor, MIDI.1~MIDI.4)
		• Line 2 - i to p indicate indicate that the switch is assigned as a Page+/Save or Page-/Save switch.

The **LED color** and **MIDI.1 ~ MIDI.4** can be set to the same procedures as the Preset switch.

4.3.6 Assign as BANK UP or BANK DOWN Switch

When the switch is assigned as the Bank Up or Bank Down, the bank number increases/decreases by one when the switch is pressed.

This page allows you to set the LED color and four MIDI messages.

	a b c d e f g h i j k l m n o p	
1	PG1.SW8 SW.Type	• Line 1 - a to g indicate the switch that is going to be created/modified.
2	= Bank+	• Line 1 - i to p indicate the details that can be set when the switch is assigned to the Bank Up or Bank Down switch. (LedColor, MIDI.1~MIDI.4)
		• Line 2 - l to p indicate indicate that the switch is assigned as the Bank Up or Bank Down switch.

The **LED color** and **MIDI.1 ~ MIDI.4** can be set to the same procedures as the Preset switch.

4.3.7 Assign as VOLUME.A+/A- or VOLUME.B+/B- Switch

When the switch is assigned as the Volume.A+/A- or Volume.B+/B-, the corresponding volume value increases/decreases by 0.5dB when the switch is pressed.

This page allows you to set the LED color and four MIDI messages.

	a b c d e f g h i j k l m n o p	
1	PG4.SW3 SW.Type	<ul style="list-style-type: none">• Line 1 - a to g indicate the switch that is going to be created/modified.• Line 1 - i to p indicate the details that can be set when the switch is assigned to the Volume.A+/A- or Volume.B+/B- switch. (LedColor, MIDI.1~MIDI.4)• Line 2 - k to p indicate indicate that the switch is assigned as the Volume.A+/A- or Volume.B+/B- switch.
2	= Vol.A+	

The **LED color** and **MIDI.1 ~ MIDI.4** can be set to the same procedures as the Preset switch.

4.3.8 Assign as BPM+ or BPM- Switch

When the switch is assigned as the BPM+ or BPM-, the BPM value increases/decreases by one when the switch is pressed.

- When EFX-LE II is operating in Preset mode, pressing this switch controls **Preset.BPM**.
- When EFX-LE II is operating in Song or Set mode, pressing this switch controls **Song.BPM**.

This page allows you to set the LED color and four MIDI messages.

	a b c d e f g h i j k l m n o p	
1	PG4.SW8 SW.Type	<ul style="list-style-type: none">• Line 1 - a to g indicate the switch that is going to be created/modified.• Line 1 - i to p indicate the details that can be set when the switch is assigned to the BPM+ or BPM- switch. (LedColor, MIDI.1~MIDI.4)• Line 2 - m to p indicate indicate that the switch is assigned as the BPM+ or BPM- switch.
2	= BPM+	

The **LED color** and **MIDI.1 ~ MIDI.4** can be set to the same procedures as the Preset switch.

4.4 TITLES MENU

The **Titles** menu allows custom titles to be entered for each presets, songs, sets, pages and switches. Each custom title can be up to 12 characters in length.

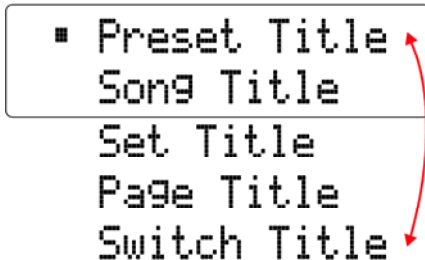

SW #5 & SW #8	Moving the selected blinking menu.
SW #6	Entering the selected menu.
SW #7	Rerutning to the Setup menu.

4.4.1 PRESET TITLE

The page allows a custom preset title, up to 12 characters in length, to be created/modified for each of the all presets.



- Line 1 - a to c and Line 2 - a to c indicate the preset that is going to be created/modified. (**001~640** or **GLB**)
- Line 1 - e to p indicate the available characters.
- Line 2 - e to p indicate the preset title.

SW #1 & SW #2	Moving the selected blinking area or cursor.
SW #3 & SW #4	When the cursor is visible on the LCD screen : Moving through the available characters.
SW #5 & SW #8	When blinking at the Line 1 and 2 - a to c : Decreasing/increasing the preset number. When the cursor is visible on the LCD screen : Moving through the available other characters.
	<pre> !"#%&'()*+ 89:;<=>?@ABC PQRSTUVWXYZI hijklmnopqrs , - . / 0 1 2 3 4 5 6 7 DEFGHIJKLMNO %] ^ _ ` abcdefg tuvwxyz{ } </pre>
SW #6	Storing any changes made while in this menu.
SW #7	Returning to the TITLES menu.

4.4.2 SONG TITLE

The page allows a custom song title, up to 12 characters in length, to be created/modified for each of the all songs.



- Line 1 - a to c and Line 2 - a to c indicate the song that is going to be created/modified. (**001~480**)
- Line 1 - e to p indicate the available characters.
- Line 2 - e to p indicate the song title.

SW #1 & SW #2	Moving the selected blinking area or cursor.
SW #3 & SW #4	When the cursor is visible on the LCD screen : Moving through the available characters.
SW #5 & SW #8	When blinking at the Line 1 and 2 - a to c : Decreasing/increasing the song number. When the cursor is visible on the LCD screen : Moving through the available other characters.
	<pre> ! "# \$ % & ' () * + 8 9 : ; < = > ? @ A B C P Q R S T U V W X Y Z [h i j k l m n o p q r s , - . / 0 1 2 3 4 5 6 7 D E F G H I J K L M N O #] ^ _ ` a b c d e f g t u v w x y z { } </pre>
SW #6	Storing any changes made while in this menu.
SW #7	Returning to the TITLES menu.

4.4.3 SET TITLE

The page allows a custom set title, up to 12 characters in length, to be created/modified for each of the all sets.

a b c d e f g h i j k l m n o p

1	SET _ ! "# \$ % & ' () * +	<ul style="list-style-type: none"> • Line 1 - a to c and Line 2 - a to c indicate the preset that is going to be created/modified. (01-60) • Line 1 - e to p indicate the available characters. • Line 2 - e to p indicate the set title.
2	01 = _ Set 01	

SW #1 & SW #2	Moving the selected blinking area or cursor.
SW #3 & SW #4	When the cursor is visible on the LCD screen : Moving through the available characters.
SW #5 & SW #8	When blinking at the Line 1 and 2 - a to c : Decreasing/increasing the set number. When the cursor is visible on the LCD screen : Moving through the available other characters.
	<pre> ! "# \$ % & ' () * + 8 9 : ; < = > ? @ A B C P Q R S T U V W X Y Z [h i j k l m n o p q r s , - . / 0 1 2 3 4 5 6 7 D E F G H I J K L M N O #] ^ _ ` a b c d e f g t u v w x y z { } </pre>
SW #6	Storing any changes made while in this menu.
SW #7	Returning to the TITLES menu.

4.4.4 PAGE TITLE

The page allows a custom page title, up to 12 characters in length, to be created/modified for each of the all pages.

a b c d e f g h i j k l m n o p

1	PG1 = _ ! "# \$ % & ' () * +	<ul style="list-style-type: none"> • Line 2 - a to c indicate the song that is going to be created/modified. (PG1-PG6) • Line 1 - e to p indicate the available characters. • Line 2 - e to p indicate the page title.
2	PG1 = _ Page.1	

SW #1 & SW #2	Moving the selected blinking area or cursor.
SW #3 & SW #4	When the cursor is visible on the LCD screen : Moving through the available characters.
SW #5 & SW #8	When blinking at the Line 1 and 2 - a to c : Decreasing/increasing the page number. When the cursor is visible on the LCD screen : Moving through the available other characters.
	<pre> !"#%&'()*+ ,-. /01234567 89:;<=>?@ABC DEFGHIJKLMNO PQRSTUVWXYZI %]^_`abcdefg hijklmnopqrs tuvwxyz{ } </pre>
SW #6	Storing any changes made while in this menu.
SW #7	Returning to the TITLES menu.

4.4.5 SWITCH TITLE

The page allows a custom switch title, up to 12 characters in length, to be created/modified for each of the all switches.

a b c d e f g h i j k l m n o p

1	PG1 _ !"#%&'()*+ .	<ul style="list-style-type: none"> Line 1 - a to c and Line 2 - a to c indicate the preset that is going to be created/modified. (PG1 SW1 ~ PG6 EX2) Line 1 - e to p indicate the available characters. Line 2 - e to p indicate the switch title.
2	SW1= _ Preset1	

SW #1 & SW #2	Moving the selected blinking area or cursor.
SW #3 & SW #4	When the cursor is visible on the LCD screen : Moving through the available characters.
SW #5 & SW #8	When blinking at the Line 1 and 2 - a to c : Decreasing/increasing the switch number. When the cursor is visible on the LCD screen : Moving through the available other characters.
	<pre> !"#%&'()*+ ,-. /01234567 89:;<=>?@ABC DEFGHIJKLMNO PQRSTUVWXYZI %]^_`abcdefg hijklmnopqrs tuvwxyz{ } </pre>
SW #6	Storing any changes made while in this menu.
SW #7	Returning to the TITLES menu.

4.5 GLOBAL MENU

The **Global** menu allows configuring the EFX-LE II's general functionality by selecting its MIDI, Audio and Others.

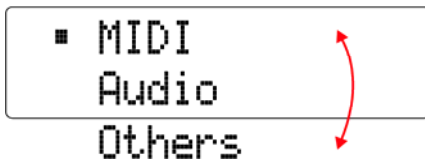

SW #5 & SW #8	Moving the selected blinking menu.
SW #6	Entering the selected menu.
SW #7	Rerutning to the Setup menu.

4.5.1 MIDI

PC Offset

There are two ways to display MIDI Program Change Number (from 0 to 127 or from 1 to 128). This page allows displaying by specifying a minimum value for Program Change Number.

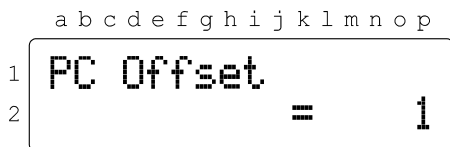

- Line 1 - a to i indicate that the PC Offset is selected.
- Line 2 - p indicates the PC Offset number. (**0** or **1**)

SW #1 & SW #2	Moving the selected blinking area.
SW #5 & SW #8	Increase or decrease the selected item.
SW #6	Storing any changes made while in this menu.
SW #7	Rerutning to the Global menu.

MIDI IN/OUT

MIDI IN Channel : The MIDI channel that the EFX-LE II will respond to incoming MIDI messages on.

MIDI OUT : MIDI data in the EFX-LE II are transmitted via the **MIDI OUT** connector.

MIDI THRU : MIDI data received at the **MIDI IN** connector pass through via the **MIDI OUT** connector without any changes.

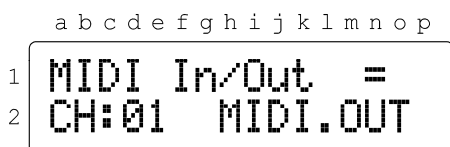

- Line 1 - a to k indicate that the MIDI IN/OUT is selected.
- Line 2 - d and e indicate the MIDI channel the EFX-LE II will receive. (**01-16** or **OFF**)
- Line 2 - m to p indicate **OUT** or **THRU**.

Time Clock

This page allows determining whether or not to transmit or receive the **MIDI TIME CLOCK** message.



- Line 1 - a to j indicate that the MIDI Time Clock is selected.
- Line 2 - e to g indicate whether or not to transmit. (**ON** or **OFF**)
- Line 2 - n to p indicate whether or not to receive. (**ON** or **OFF**)

XPDL

This page allows determining whether you connect an expression pedal or two foot-switches to the **XPDL** jack. You can also set the MIDI Control Change that is sent when an expression pedal is connected.

```
  a b c d e f g h i j k l m n o p
1  XPDL=SW
2
```

- Line 1 - a to d indicate that the **XPDL** is selected.
- Line 1 - f and g indicate '**Two Foot-switches**'.

```
  a b c d e f g h i j k l m n o p
1  XPDL=PD C01 #OFF
2  Mx127 Mn000 10ms
```

- Line 1 - a to d indicate that the **XPDL** is selected.
- Line 1 - f and g indicate '**Expression Pedal**'.
- Line 1 - j and k indicate the MIDI Control Change Channel. (**01~16**)
- Line 1 - n to p indicate the MIDI Controller Number. (**000~127** or **OFF**)
- Line 2 - c to e indicate indicate the highest **XPDL** value that the expression pedal port can transmit when its pedal is moved. (**000~127**)
- Line 2 - i to k indicate indicate the lowest **XPDL** value that the expression pedal port can transmit when its pedal is moved. (**000~127**)
- Line 1 - j and k indicate a **XPDL Rate** value. (**00~20**)

Tempo.CC

Some MIDI devices receive **MIDI Control Change**, not **MIDI TIME CLOCK**, as the tempo message. This page lets you set the MIDI Control Change as a tempo for these units.

```
  a b c d e f g h i j k l m n o p
1  Tempo.CC = C01
2  #OFF NvOFF FvOFF
```

- Line 1 - a to h indicate that the Tempo.CC is selected.
- Line 1 - o and p indicate the MIDI Control Change channel (**01~16**).
- Line 2 - b to d indicate the MIDI Controller number. (**000~127** or **OFF**)
- Line 2 - h to j indicate the MIDI Controller on value. (**000~127** or **OFF**)
- Line 2 - n to p indicate the MIDI Controller off value. (**000~127** or **OFF**)

MIDI.Pause

Some MIDI devices miss MIDI messages when they receive continuous MIDI messages. This page allows the EFX-LEII to pause sending midi messages for as long as you set when sending them to a specific channel.

```
  a b c d e f g h i j k l m n o p
1  MIDI Pause =
2  CH:OFF TIME:00ms
```

- Line 1 - a to j indicate that the MIDI Pause is selected.
- Line 2 - d to f indicate the MIDI Channel to use the pause function (**01~16** or **OFF**)
- Line 2 - m and n indicate the time to pause. (**00~50ms**)

4.5.2 AUDIO

Clickless

The **Clickless** control is excellent for reducing this a popping noise. This page allows determining the position that this control will be used.

a b c d e f g h i j k l m n o p	
1 Clickless 2 = Outputs	<ul style="list-style-type: none"> • Line 1 - a to p indicate that the Clickless is selected. • Line 2 - f to p indicate the Clickless position. (<i>Off</i>, <i>VL.Send</i> or <i>Outputs</i>)

SW #1 & SW #2	Moving the selected blinking area.
SW #5 & SW #8	Increase or decrease the selected item.
SW #6	Storing any changes made while in this menu.
SW #7	Rerutning to the Global menu.

Loop 5/6 Return

This page lets you set whether effect loop 5 and 6 are **MONO-Return** or **STEREO-Return**.

a b c d e f g h i j k l m n o p	
1 Loop5 Return 2 = Mono	<ul style="list-style-type: none"> • Line 1 - a to p indicate that the Loop5/6 Return is selected. • Line 2 - f to p indicate Mono or Stereo.

Loop 6 Send

This page lets you set whether the **SND6-Left** signal is split up in to the **SND6-Right**.

a b c d e f g h i j k l m n o p	
1 Loop6 Send 2 = Mono	<ul style="list-style-type: none"> • Line 1 - a to p indicate that the Loop6 Send is selected. • Line 2 - f to p indicate Mono or Stereo.

* When you use a Stereo IN/OUT effect pedal in the Loop 6, this page must be **Stereo**.
 When you use a Mono IN/Stereo OUT or Mono IN/OUT effect pedal in the Loop 6, this page must be **Mono**.

Func.Switch 1/2

The **F1** and **F2** will act as footswitches like those used for amp channel switching. The EFX-LE II supports three types of switch. (**Latched**, **Momentary** and **TempoSync**)

When set to **TempoSync**, it is synchronized with the **BPM**.

a b c d e f g h i j k l m n o p	
1 Func.Switch 1 2 = Latched	<ul style="list-style-type: none"> • Line 1 - a to p indicate that the Func.Switch 1/2 is selected. • Line 2 - f to p indicate a function switch type. (<i>Latched</i>, <i>Momentary</i> or <i>TempoSync</i>).

ISO-OUT Source

This page lets you set which signal is split to the **ISO-OUT** jack.

```

a b c d e f g h i j k l m n o p
1 ISO-OUT Source
2 =          OUT.R
  
```

- Line 1 - a to p indicate that the ISO-OUT Source is selected.
- Line 2 - f to p indicate which signal is split to the ISO-OUT jack. (**OUT.R**, **VL.Send** or **VL.Return**).

Parallel Control

This page lets you set the switching method when the loops are connected in parallel.

```

a b c d e f g h i j k l m n o p
1 Parallel Control
2 = Snd & Rtn
  
```

- Line 1 - a to p indicate that the Parallel Control is selected.
- Line 2 - f to p indicate the switching method when connecting in Parallel. (**Snd & Rtn**, **Snd**).

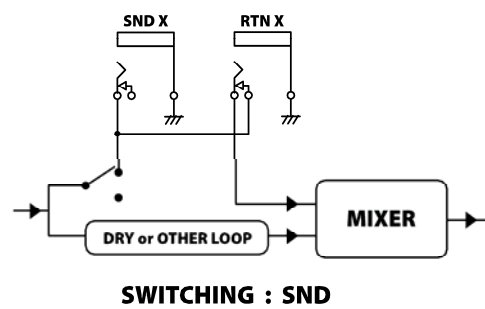
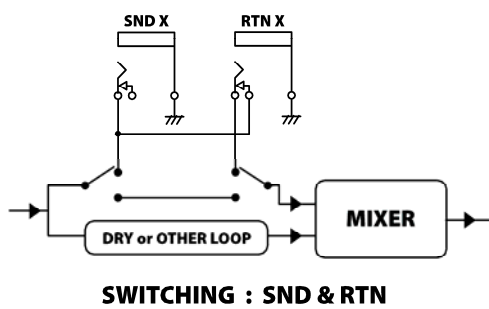

4.5.3 OTHERS

Operate Mode

This page allows determining the operating mode of the EFX-LE II.

a b c d e f g h i j k l m n o p

1	Operate Mode	
2	=	Preset

- Line 1 - a to p indicate that the Operate Mode is selected.
- Line 2 - f to p indicate the Operate Mode.
(*Preset, Song* or *Set01~Set60*)

PST 2nd Press

This page allows determining whether you want to select the global preset or go to the last page when you press a switch in the preset that is already on.

a b c d e f g h i j k l m n o p

1	PST 2nd Press	
2	=	GlobalPST

- Line 1 - a to p indicate that the PST 2nd Press is selected.
- Line 2 - f to p indicate a selected item.
(*GlobalPST, Last Page* or *None*)

Preset/BnkSng

This page allows determining how many presets you will use for a bank or song.

a b c d e f g h i j k l m n o p

1	Preset/BnkSng	
2	=	4

- Line 1 - a to p indicate that the Preset/BnkSng is selected.
- Line 2 - p indicates the number of presets.
(*3 to 5*)

Maximum Page & Bank

This page allows determining how many pages or banks you will access.

a b c d e f g h i j k l m n o p

1	Maximum Page	
2	=	4

- Line 1 - a to p indicate that the Maximum Page is selected.
- Line 2 - p indicates the number of pages.
(*1 to 6*)

a b c d e f g h i j k l m n o p

1	Maximum Bank	
2	=	160

- Line 1 - a to p indicate that the Maximum Bank is selected.
- Line 2 - f to p indicate a selected item.
(*1 to 160*)

Ext.Switches

This page allows determining whether the operation of the external switch acts as the setting of each page or as the setting of page 1.

a b c d e f g h i j k l m n o p

1	Ext.Switches	
2	=	Each Page

- Line 1 - a to l indicate that the Ext.Switches is selected.
- Line 2 - h to p indicate whether to use the settings of each page or the settings of page 1. (*Each Page* or *Page.1*)

4.6 UTILITY MENU

The **UTILITY** menu allows configuring Copy, Data Dump/Load and Factory Reset.

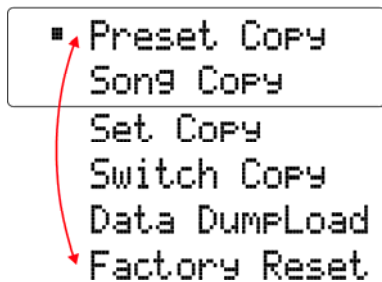

SW #5 & SW #8	Moving the selected blinking menu.
SW #6	Entering the selected menu.
SW #7	Rerutning to the Setup menu.

4.6.1 PRESET COPY

This page allows copying part or all of the data from one preset to another.



- Line 1 - d to i indicate the copy source preset.
- Line 1 - l to p indicate part or all of the data the copy source preset. (**All**, **Audio**, **MIDI** or **Title**)
- Line 2 - d to i indicate the start preset of the copy destination preset.
- Line 2 - k to p indicate the end preset of the copy destination preset.

SW #1 & SW #2	Moving the selected blinking area.
SW #5 & SW #8	Increase or decrease the selected item.
SW #6	Copying any changes made while in this menu.
SW #7	Rerutning to the Utility menu.

4.6.2 SONG/SET/SWITCH COPY

This page allows copying from one song/set/swtich to another.

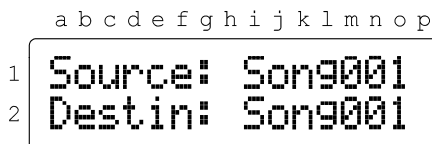

- Line 1 - i to o indicate the copy source song.
- Line 2 - i to o indicate the copy destination song.

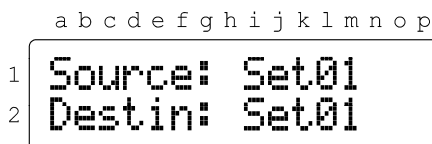

- Line 1 - i to m indicate the copy source set.
- Line 2 - i to m indicate the copy destination set.



- Line 1 - h to p indicate the copy source switch.
- Line 2 - h to p indicate the copy destination switch.

4.6.1 DATA DUMP/LOAD

This page allows the EFX-LE II user data to be dumped (transmitted) to a computer or another EFX-LE II, via this unit's **MIDI OUT/THRU** jack. User data will be transmitted as a MIDI sysex (system exclusive) message. Also this sub-menu allows the EFX-LE II user data to be loaded (received) from a computer or another EFX-LE II, via this unit's **MIDI IN** jack. User data will be received as a **MIDI sysex (system exclusive)** message.

	a b c d e f g h i j k l m n o p	
1	Data DUMP/Load	<ul style="list-style-type: none"> • Line 1 - a to n indicate that Data Dump/Load page is selected. • Line 2 - m to p indicate that Data Load is selected.
2	= Load	

SW #5 & SW #8	Increase or decrease the selected item.
SW #7	Rerutning to the Utility menu.

	a b c d e f g h i j k l m n o p	
1	Data DUMP/Load	<ul style="list-style-type: none"> • Line 1 - a to n indicate that Data Dump/Load page is selected. • Line 2 - m to p indicate that Data Dump is selected.
2	= DUMP	

SW #5 & SW #8	Increase or decrease the selected item.
SW #6	Starting data dump.
SW #7	Rerutning to the Utility menu.

* When connecting the EFX-LE II to a PC, the **Roland UM-ONE** and the **M-Audio USB UNO 1x1** are recommended. These MIDI interfaces have been tested for compatibility with the EFX-LE II.

4.6.1 FACTORY RESET

This page allows erasing selected user data area in the internal EEPROM memory.

	a b c d e f g h i j k l m n o p	
1	Factory Reset	<ul style="list-style-type: none"> • Line 1 - a to n indicate that Factory Reset page is selected. • Line 2 - n to p indicate OFF or ON.
2	= OFF	

SW #5 & SW #8	Increase or decrease the selected item.
SW #6	Starting factory reset.
SW #7	Rerutning to the Utility menu.

5. Cables

5.1 XPDL

XPDL & Expression Pedal

The cable required is a stereo (TRS) to a stereo (TRS) 1/4" phone plugs.

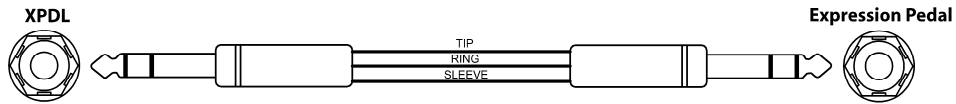

* Do not use an active volume pedal or expression pedal.

XPDL & Volume Pedal

Passive volume pedals can be used as an expression pedal. The cable required is a stereo (TRS) to two mono (TS) 1/4" phone plugs. Connect the tip(stereo plug) to the pedal output, ring to the pedal input and sleeve to ground on all 3 plugs.

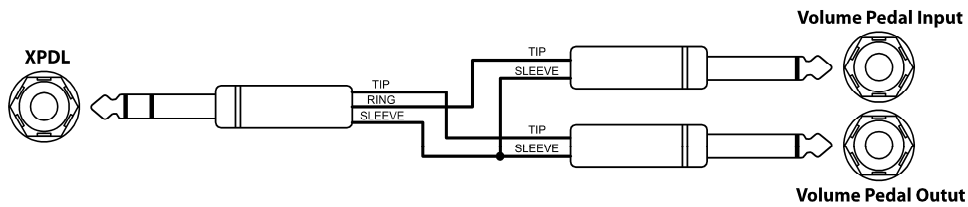

* Do not use an active volume pedal or expression pedal.

XPDL & Two Foot-switches

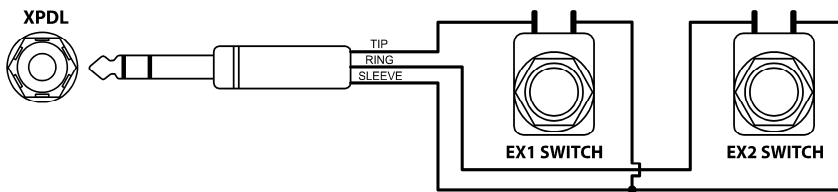

* Connect the Normally Open Momentary switches when connecting external switches.

5.2 Functions Switches

The cable required is a stereo (TRS) to two mono 1/4" phone plugs.

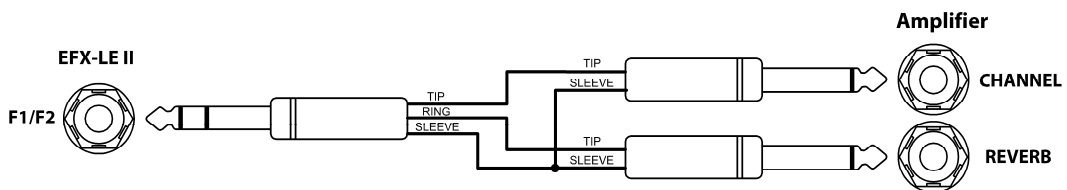

6. MIDI IN Specification

6.1 MIDI Preset Changes

MIDI access to these presets is available as MIDI program change messages. Via MIDI, the presets are numbered sequentially.

PRESET MODE	SONG MODE	SET MODE
<p>CC#:032 VALUE:000</p> <p>PRESET 001 PC # 001</p> <p>PRESET 002 PC # 002</p> <p>PRESET 003 PC # 003</p> <p>PRESET 004 PC # 004</p> <p>...</p> <p>PRESET 127 PC # 127</p> <p>PRESET 128 PC # 128</p> <p>CC#:032 VALUE:001</p> <p>PRESET 129 PC # 001</p> <p>PRESET 130 PC # 002</p> <p>...</p> <p>PRESET 255 PC # 127</p> <p>PRESET 256 PC # 128</p> <p>CC#:032 VALUE:004</p> <p>PRESET 513 PC # 001</p> <p>PRESET 514 PC # 002</p> <p>...</p> <p>PRESET 639 PC # 127</p> <p>PRESET 640 PC # 128</p>	<p>CC#:000 VALUE:000 CC#:032 VALUE:000</p> <p>SONG 001 - P1 PC # 001</p> <p>SONG 001 - P2 PC # 002</p> <p>SONG 001 - P3 PC # 003</p> <p>SONG 001 - P4 PC # 004</p> <p>CC#:000 VALUE:000 CC#:32 VALUE:127</p> <p>SONG 128 - P1 PC # 001</p> <p>SONG 128 - P2 PC # 002</p> <p>SONG 128 - P3 PC # 003</p> <p>...</p> <p>CC#:000 VALUE:002 CC#:32 VALUE:000</p> <p>SONG 257 - P1 PC # 001</p> <p>SONG 257 - P2 PC # 002</p> <p>...</p> <p>CC#:000 VALUE:003 CC#:32 VALUE:095</p> <p>SONG 480 - P1 PC # 001</p> <p>SONG 480 - P2 PC # 002</p> <p>SONG 480 - P3 PC # 003</p> <p>SONG 480 - P4 PC # 004</p>	<p>CC#:032 VALUE:000</p> <p>SONG 01 - P1 PC # 001</p> <p>SONG 01 - P2 PC # 002</p> <p>SONG 01 - P3 PC # 003</p> <p>SONG 01 - P4 PC # 004</p> <p>CC#:032 VALUE:001</p> <p>SONG 02 - P1 PC # 001</p> <p>SONG 02 - P2 PC # 002</p> <p>SONG 02 - P3 PC # 003</p> <p>...</p> <p>CC#:032 VALUE:033</p> <p>SONG 34 - P1 PC # 001</p> <p>SONG 34 - P2 PC # 002</p> <p>...</p> <p>CC#:032 VALUE:047</p> <p>SONG 48 - P1 PC # 001</p> <p>SONG 48 - P2 PC # 002</p> <p>SONG 48 - P3 PC # 003</p> <p>SONG 48 - P4 PC # 004</p>

- * **CC#000** and **CC#032** are *MIDI BANK SELECT MSB* and *LSB* messages.
- * **Preset** mode : **Preset #** = (LSB x 128) + PC #
- * **Song** mode : **Song #** = (MSB x 128) + LSB + 1 , **Preset** = PC #
- * **Set** mode : **Song #** = LSB + 1 , **Preset** = PC #

6.2 Individual IA Switch Controls

The IA switches can be controlled with MIDI Control Change messages. Only possible if the switch is assigned an IA switch.

CC # CALCULATION	VALUE RANGE
CC Number = 10 x Page Number + Switch Number + 29	OFF(0-63) ON(64-127)

For Example : Page 4 and Switch #2
 $10 \times 4 + 2 + 29 = \text{CC} \# 71$

7. CONNECTION EXAMPLES

Basic Mono Connection

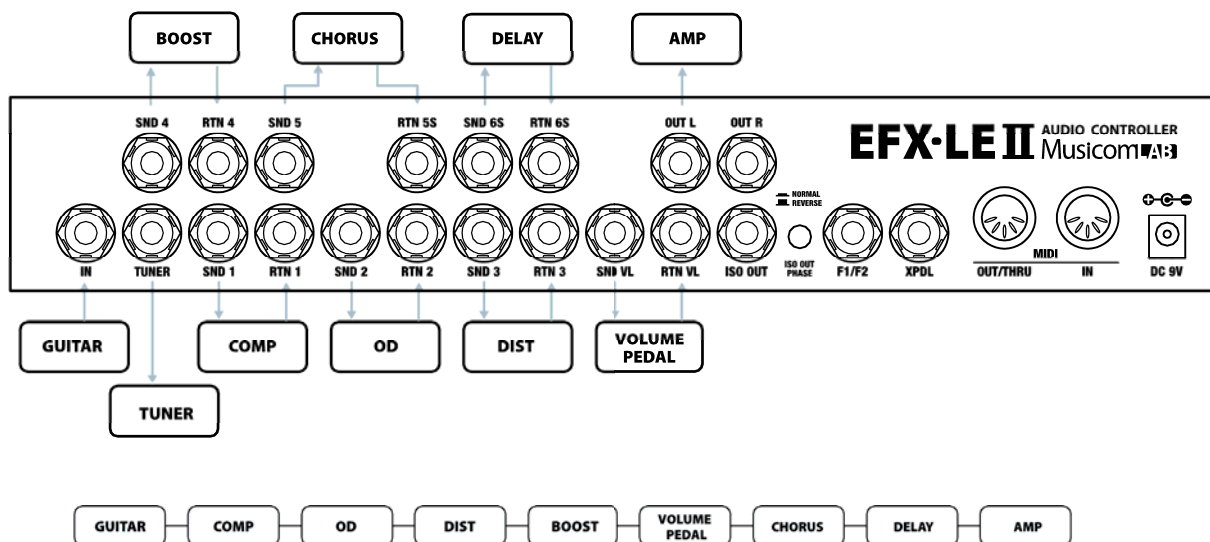

Mono Connection for 2 Amps

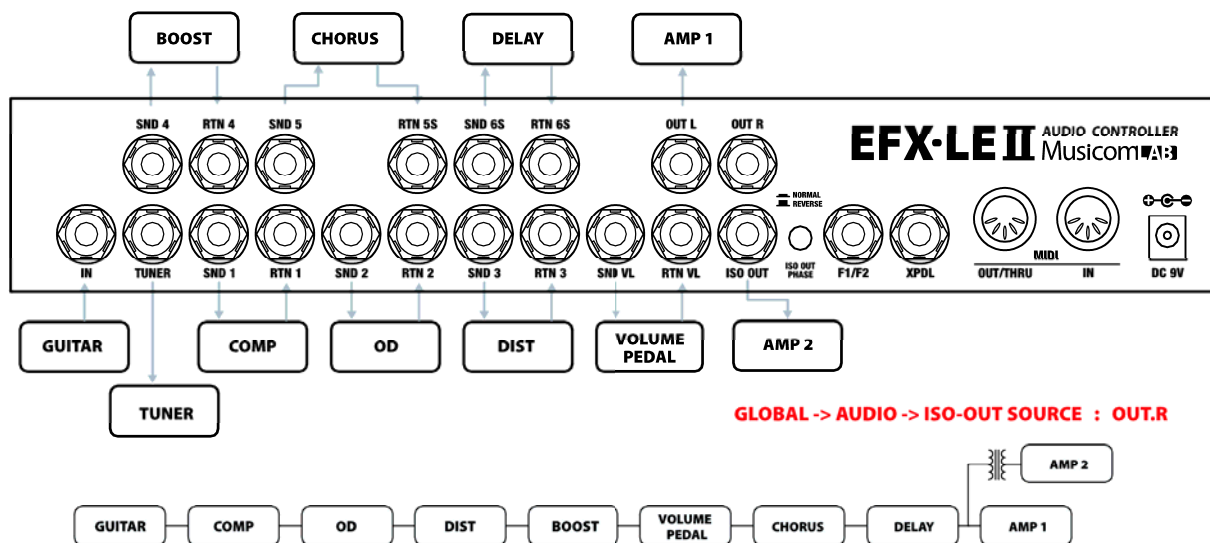

Mono Connection for 4CM

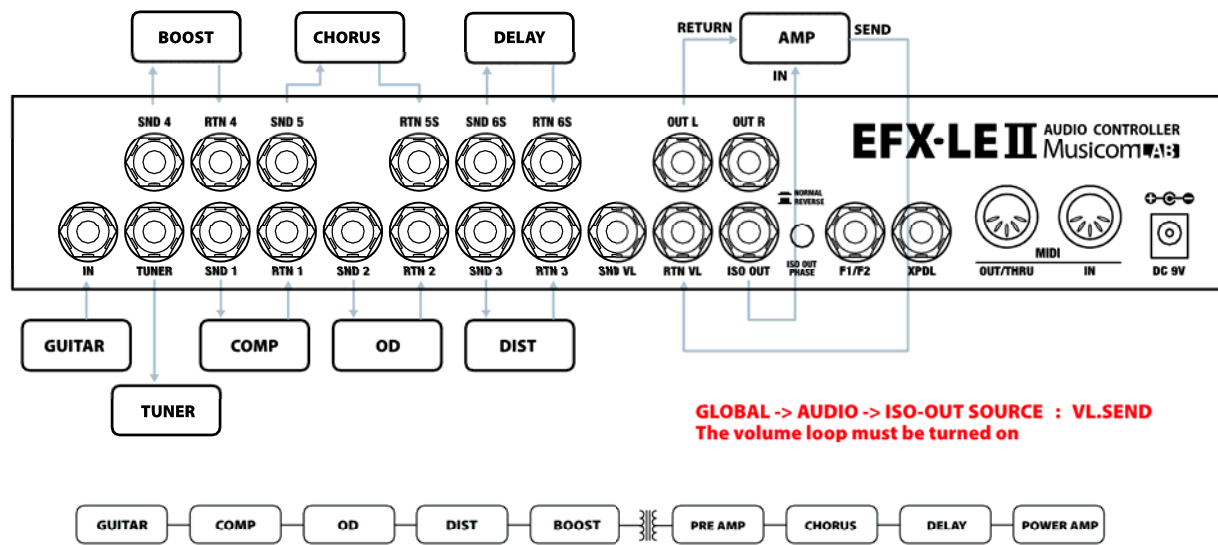

Basic Stereo Connection

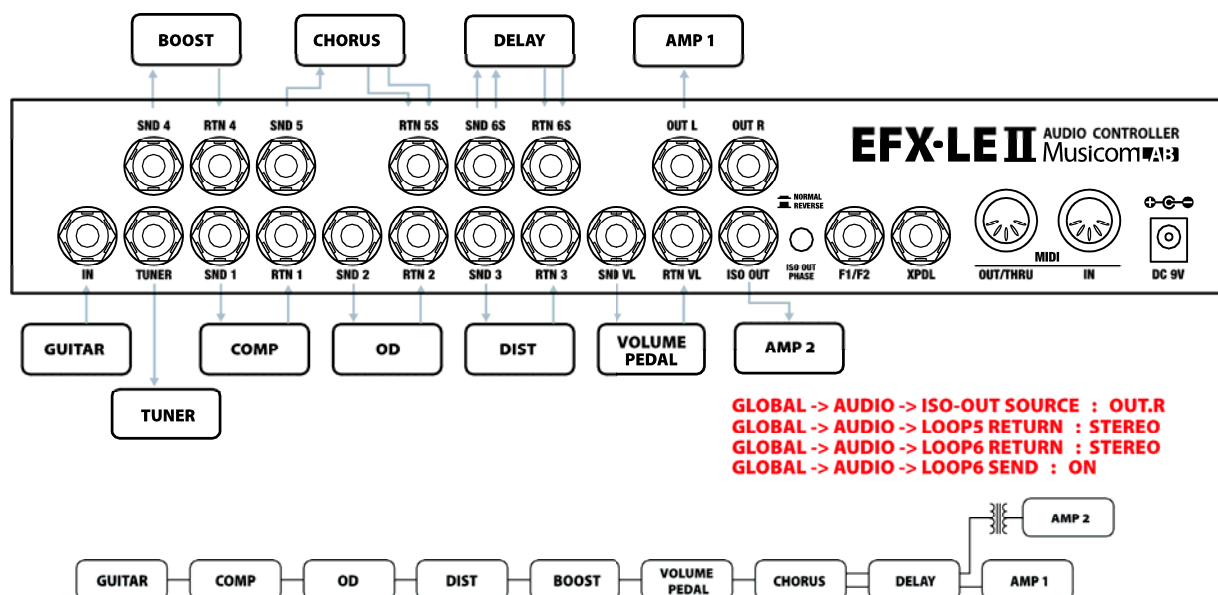

SAFETY PRECAUTIONS



WARNING

- To reduce the risk of fire or electric shock, do not expose this appliance to rain or moisture.
- Do not cause electrostatic discharge (ESD) to the device.

CAUTION

- To reduce the risk of fire or electric shock, do not remove screws.
- There are no user serviceable parts inside.
- This device includes components which are susceptible to damage by electrostatic discharge (ESD).
- Refer servicing to qualified service personnel.

WARRANTY

Musicom Lab warrants this product against any defects that are due to defective parts or faulty workmanship for a period of one year from the date of original retail purchase. During this one year period, Musicom Lab will repair it without charge for parts or labor. However shipping charges to and from the repair location must be paid by the owner.

- This warranty applies only to the original owner and is not transferable.
- This warranty does not include damage to the product resulting from accident or misuse.
- This warranty shall not apply to any goods that have been repaired or altered by anyone other than the manufacturer.

Contact the following for support and/or repair service.

Mail : Musicom Lab
15-4, Seooreung-ro 15-gil, Eunpyeong-gu, Seoul, 03426, South Korea

Website : <http://www.musicomlab.com>

Email : support@musicomlab.com

Facebook : www.facebook.com/musicomlab